

PARKING DESIGN

I. GENERAL REQUIREMENTS

A. STALL WIDTHS

1. Minimum 8 ft 6 inches wide for standard stalls serving dwelling units.
2. Minimum 8 ft 4 inches wide for all other standard stalls.
3. Minimum 8 ft 0 inches wide for all parallel parking standard stalls.
4. Minimum 7 ft 6 inches wide for all compact stalls.
5. For disabled access stall widths and other requirements, refer to Information Bulletin P/BC 2023-084.
6. Stall widths must be increased 10 inches for obstructions, except for stalls serving single family dwellings and duplexes, as shown in Figures 8 & 9 and shall be increased for end stall conditions as shown in Figures 2 and 3 in section N. For purposes of determining increases for obstructions, property lines shall be considered as obstructions. No increase for obstructions is required for parallel parking stalls.

B. STALL DEPTHS

1. Minimum 18 feet deep for all standard stalls.
2. Minimum 15 feet deep for all compact stalls.
3. Minimum 26 feet deep for all standard parallel stalls and 30 feet deep for end parallel stalls.
4. Minimum 23 feet deep for all compact parallel stalls and 27 feet deep for end parallel stalls.

C. COMPACT PARKING SPACES PERMITTED

In parking areas or garages containing 10 or more spaces for other than dwelling uses, up to 40% of the total required parking spaces and 100% of the non-required parking spaces may be compact. For dwelling uses, all parking stalls in excess of one stall per unit may be compact. Unless specified otherwise, required guest parking spaces may be compact spaces.

D. ACCESS AISLE AND PARKING BAY WIDTHS

1. The basic access aisle and parking bay widths for compact and standard stalls are shown in Tables 1 through 6.

2. Parking bay dimensions shall be determined using the required basic stall width before required increases for obstructions. Where required and non-required stalls are intermixed in a bay, the width of the bay shall be the larger of the bay widths shown in the tables for the required and non-required stalls. Where single access is provided for both entrance and exit to a parking bay and the bay contains 25 stalls or less, the bay may be designed using one-way traffic tables. Where the number of stalls exceeds 25 and single access for entrance is provided, the bay widths shall be determined using the two-way traffic tables.

E. TANDEM PARKING STALLS

1. Tandem parking stalls are permitted in public garages and public parking areas providing an attendant. A “Covenant and Agreement to Provide Parking Attendant” will be required.
2. Tandem stalls are permitted in private parking garages and private parking areas provided:
 - a. At least one parking stall per dwelling unit and all stalls required for any guest parking shall be individually and easily accessible.
 - b. At least one standard stall per dwelling unit shall be provided.
3. Tandem parking shall be limited to a maximum of two cars in depth, in a private garage or private parking area, except for additional parking required in accordance with Section 12.21A17(h) or 12.21C10(g)(4).
4. When determining access aisle widths for tandem parking having both standard and compact stalls in tandem, the aisle widths for standard stalls shall be used.

F. PARKING STALL LOCATION

1. Each parking stall shall be so located that no automobile is required to back into any public street or sidewalk to leave the parking stall, parking bay, or driveway, except where such parking stalls, parking bays, or driveways serve not more than two dwelling units and where the driveway access is to a street other than a major or secondary highway.
2. No automobile parking space shall be provided or maintained within the required front yard of an A or R zoned lot except for additional parking provided in accordance with Sections 12.21A17(h) or 12.21C10(g)(2).
3. No parking stall may be located within a 5 foot side yard along the side street lot line of an A or R zoned corner lot.

G. DRIVEWAY WIDTHS AND LOCATIONS

1. Department of Transportation approval for the location of the driveways shall be obtained on lots located in a P (including any combination with an A or R Zone) or PB Zone, for all residential driveways serving two or more dwelling units which front on major and secondary highways and for all new driveways serving all other uses.
2. 9 ft. minimum in the A, RE, RS, R1, RU, RZ, R2, RMP and RW Zones.
3. 10 ft. minimum in all other zones and when serving an apartment house in the R2 Zone.

4. 19 ft. minimum when serving more than 25 cars or, in lieu thereof, there shall be two 10 ft. minimum wide driveways.
5. Not more than 50% of a required front yard shall be designed, improved or used for access driveways unless the lot is developed with a building meeting the requirements of Section 12.08.3B1 (RZ Zone requirements).

H. SLOPES FOR DRIVEWAYS, RAMPS AND STALLS

1. 20% maximum slope on driveway or ramp.
2. 10% maximum cross slope of a driveway or ramp.
3. 6.67% maximum slope in any direction in a parking stall.
4. Transition slopes are required when the slope of the driveway or ramp exceeds 12.5%. See Figures 11A and 11B for acceptable transition slope designs.

I. GARAGE DESIGN

1. DOOR OPENING WIDTHS

- a. The required garage door opening width shall be increased in the event the stall widths are increased in order to accommodate a reduced access aisle width.
- b. The required garage door opening shall be equal to the required stall width less 8 inches for a one car garage and the sum of the required stall widths, less 16 inches for a two car garage.

Exception: The required garage door opening width for a one car garage shall be 8 feet minimum. The required garage door opening width for a two car garage shall be 16 feet minimum.

- c. The required garage door opening width for all other garages shall be equal to the required driveway width or the sum of the stall widths whichever is greater.

2. CLEAR HEIGHT IN GARAGE

- a. All parking garages shall have an unobstructed headroom clearance of not less than 7 feet above the finished floor to any ceiling, beam, pipe or similar obstruction.
- b. All entrances to and vertical clearances within parking structures shall have a minimum vertical clearance of 8 feet 2 inches where required for accessibility to parking spaces for persons with physical disabilities.

J. PAVING, LANDSCAPING, AND CAR STOPS

1. Every parking area and parking garage including access driveways thereto, shall be paved with hard, durable asphaltic paving which has been mixed at a plant and is at least two inches thick after compaction or with portland cement paving at least three inches thick. **Exception:** Access driveways to the areas referenced above may be paved with a permeable material such as pavers, porous concrete, a combination of 45% concrete and 55% holes filled with grass distributed uniformly (commonly known as grasscrete), or any material deemed equivalent by the Department of City Planning.
2. All areas shall have appropriate bumper guards, wheel stops, steel posts, walls, curbs, suitable landscaping, or other installations adequate to prevent vehicles from parking or maneuvering on those portions of a lot upon which a driveway or parking area is prohibited, or into a public right of way, or where those portions of a lot are needed to prevent encroachment on walkways or adjoining properties.
3. All portions of a required front yard shall be landscaped as required by LAMC Section 12.21C1(g). A City Planning approval is required for all such landscaped areas in the RD, R3, RAS3, R4, RAS4, R5, or C zones, and when landscaping is required by any other provision of the LAMC.

K. INTERNAL CIRCULATION

All portions of a public parking area or public garage shall be accessible to all other portions thereof without requiring the use of any public street, unless the Department of Transportation determines that such use is not detrimental to the flow of traffic.

TABLE 1: STANDARD CARS - PARKING BAY WIDTHS FOR ONE-WAY TRAFFIC * AND DOUBLE LOADED AISLES, BASED ON CHART NO. 1 IN ORDINANCE NO. 142,306

Parking Angle	8'-4" Stalls	8'-6" Stalls	8'-8" Stalls	8'-10" Stalls	9'-0" Stalls	9'-2" Stalls	9'-4" Stalls
30	43'-0"	43'-0"	43'-0"	43'-0"	43'-0"	43'-0"	43'-0"
32.5	44'-2"	44'-2"	44'-2"	44'-2"	44'-2"	44'-2"	44'-2"
35	45'-3"	45'-3"	45'-3"	45'-3"	45'-3"	45'-3"	45'-3"
37.5	46'-3"	46'-3"	46'-3"	46'-3"	46'-3"	46'-3"	46'-3"
40	47'-4"	47'-0"	47'-0"	47'-0"	47'-0"	47'-0"	47'-0"
42.5	48'-10"	48'-4"	47'-10"	47'-8"	47'-8"	47'-8"	47'-8"
45	50'-3"	49'-10"	49'-5"	49'-0"	48'-7"	48'-5"	48'-5"
47.5	51'-6"	51'-1"	50'-8"	50'-3"	49'-10"	49'-5"	49'-0"
50	52'-8"	52'-3"	51'-10"	51'-5"	51'-0"	50'-6"	50'-1"
52.5	53'-8"	53'-3"	52'-10"	52'-5"	52'-0"	51'-6"	51'-1"
55	54'-7"	54'-2"	53'-9"	53'-4"	52'-11"	52'-5"	52'-0"
57.5	55'-6"	55'-0"	54'-7"	54'-1"	53'-8"	53'-2"	52'-9"
60	56'-5"	55'-11"	55'-5"	55'-0"	54'-8"	54'-0"	53'-7"
62.5	57'-4"	56'-10"	56'-4"	55'-10"	55'-4"	54'-9"	54'-5"
65	58'-2"	57'-8"	57'-2"	56'-8"	56'-2"	55'-8"	55'-2"
67.5	58'-10"	58'-3"	57'-9"	57'-3"	56'-9"	56'-3"	55'-9"
70	59'-7"	59'-0"	58'-6"	58'-0"	57'-6"	57'-0"	56'-6"
72.5	60'-3"	59'-8"	59'-2"	58'-7"	58'-1"	57'-7"	57'-1"
75	60'-11"	60'-4"	59'-9"	59'-2"	58'-8"	58'-1"	57'-7"
77.5	61'-7"	61'-0"	60'-5"	59'-10"	59'-3"	58'-8"	58'-2"
80	62'-2"	61'-7"	61'-0"	60'-5"	59'-10"	59'-3"	58'-8"
82.5	62'-8"	62'-0"	61'-5"	60'-10"	60'-3"	59'-8"	59'-1"
85	63'-2"	62'-8"	61'-11"	61'-3"	60'-8"	60'-1"	59'-6"
87.5	63'-7"	62'-11"	62'-3"	61'-7"	61'-0"	60'-4"	59'-9"
90	64'-0"	63'-4"	62'-8"	62'-0"	61'-4"	60'-8"	60'-0"

* NOTE: All values on this table are for required parking stalls. To determine parking bay widths for non-required stalls, merely use a column showing a stall width dimension that is 4 inches more. The values above the darkened lines are governed by minimum aisle width. The stall widths (8'-6", 8'-10", and 9'-2") are not shown in the ordinance, but are available for use.

TABLE 2: STANDARD CARS - PARKING BAY WIDTHS FOR ONE-WAY TRAFFIC AND SINGLE LOADED AISLES, BASED ON CHART NO. 2 IN ORDINANCE NO. 142,306 *

Parking Angle	8'-4" Stalls	8'-6" Stalls	8'-8" Stalls	8'-10" Stalls	9'-0" Stalls	9'-2" Stalls	9'-4" Stalls
30	27'-6"	27'-6"	27'-6"	27'-6"	27'-6"	27'-6"	27'-6"
32.5	28'-1"	28'-1"	28'-1"	28'-1"	28'-1"	28'-1"	28'-1"
35	28'-7"	28'-7"	28'-7"	28'-7"	28'-7"	28'-7"	28'-7"
37.5	29'-1"	29'-1"	29'-1"	29'-1"	29'-1"	29'-1"	29'-1"
40	29'-11"	29'-6"	29'-6"	29'-6"	29'-6"	29'-6"	29'-6"
42.5	30'-11"	30'-6"	30'-1"	29'-10"	29'-10"	29'-10"	29'-10"
45	31'-11"	31'-6"	30'-8"	30'-8"	30'-3"	30'-3"	30'-5"
47.5	32'-11"	32'-6"	32'-1"	31'-8"	31'-3"	31'-10"	30'-5"
50	33'-10"	33'-5"	33'-0"	32'-7"	32'-2"	31'-9"	31'-4"
52.5	34'-9"	34'-3"	33'-9"	33'-4"	32'-11"	32'-6"	32'-1"
55	35'-7"	35'-1"	34'-7"	34'-2"	33'-8"	33'-3"	32'-10"
57.5	36'-5"	35'-11"	35'-5"	35'-0"	34'-6"	34'-0"	33'-7"
60	37'-3"	36'-9"	36'-3"	35'-9"	35'-3"	34'-9"	34'-4"
62.5	38'-0"	37'-6"	37'-0"	36'-6"	36'-0"	35'-6"	35'-0"
65	38'-9"	38'-2"	37'-8"	37'-2"	36'-8"	36'-2"	35'-8"
67.5	39'-6"	38'-11"	38'-5"	37'-11"	37'-4"	36'-10"	36'-4"
70	40'-3"	39'-8"	39'-2"	38'-7"	38'-1"	37'-6"	37'-0"
72.5	40'-11"	40'-4"	39'-10"	39'-3"	38'-9"	38'-2"	37'-8"
75	41'-8"	41'-1"	40'-7"	40'-0"	39'-5"	38'-10"	38'-4"
77.5	42'-5"	41'-10"	41'-3"	40'-8"	40'-1"	39'-6"	39'-0"
80	43'-1"	42'-6"	41'-11"	41'-4"	40'-9"	40'-2"	39'-7"
82.5	43'-9"	43'-1"	42'-6"	41'-11"	41'-4"	40'-9"	40'-2"
85	44'-6"	43'-10"	43'-3"	42'-7"	42'-0"	41'-4"	40'-9"
87.5	45'-3"	44'-7"	43'-11"	43'-4"	42'-8"	42'-0"	41'-5"
90	46'-0"	45'-4"	44'-8"	44'-0"	43'-4"	42'-8"	42'-0"

* NOTE: All values on this table are for required parking stalls. To determine parking bay widths for non-required stalls, merely use a column showing a stall width dimension that is 4 inches more. The values above the darkened lines are governed by minimum aisle width. The stall widths (8'-6", 8'-10", and 9'-2") are not shown in the ordinance, but are available for use.

TABLE 3: STANDARD CARS - PARKING BAY WIDTHS FOR TWO-WAY TRAFFIC AND DOUBLE LOADED AISLES, BASED ON CHART NO. 3 IN ORDINANCE NO. 142,306 *

Parking Angle	8'-4" Stalls	8'-6" Stalls	8'-8" Stalls	8'-10" Stalls	9'-0" Stalls	9'-2" Stalls	9'-4" Stalls
30	51'-2"	51'-2"	51'-2"	51'-2"	51'-2"	51'-2"	51'-2"
32.5	52'-4"	52'-4"	52'-4"	52'-4"	52'-4"	52'-4"	52'-4"
35	53'-3"	53'-3"	53'-3"	53'-3"	53'-3"	53'-3"	53'-3"
37.5	54'-2"	54'-2"	54'-2"	54'-2"	54'-2"	54'-2"	54'-2"
40	54'-10"	54'-10"	54'-10"	54'-10"	54'-10"	54'-10"	54'-10"
42.5	55'-7"	55'-7"	55'-7"	55'-7"	55'-7"	55'-7"	55'-7"
45	56'-4"	56'-4"	56'-4"	56'-4"	56'-4"	56'-4"	56'-4"
47.5	57'-0"	57'-0"	57'-0"	57'-0"	57'-0"	57'-0"	57'-0"
50	57'-8"	57'-8"	57'-7"	57'-7"	57'-0"	57'-6"	57'-6"
52.5	58'-4"	58'-3"	58'-2"	58'-2"	58'-1"	58'-0"	58'-0"
55	58'-11"	58'-9"	58'-8"	58'-7"	58'-6"	58'-5"	58'-4"
57.5	59'-6"	59'-4"	59'-2"	59'-1"	58'-11"	58'-9"	58'-8"
60	59'-11"	59'-9"	59'-7"	59'-5"	59'-3"	59'-1"	58'-11"
62.5	60'-5"	60'-2"	60'-0"	59'-9"	59'-7"	59'-4"	59'-2"
65	60'-11"	60'-8"	60'-5"	60'-2"	59'-11"	59'-8"	58'-5"
67.5	61'-5"	61'-1"	60'-9"	60'-6"	60'-2"	59'-10"	59'-7"
70	61'-10"	61'-5"	61'-1"	60'-9"	60'-5"	60'-1"	59'-9"
72.5	62'-3"	61'-10"	61'-5"	61'-0"	60'-7"	60'-2"	59'-10"
75	62'-7"	62'-1"	61'-8"	61'-3"	60'-9"	60'-4"	59'-11"
77.5	62'-11"	62'-5"	61'-11"	61'-5"	60'-11"	60'-5"	60'-0"
80	63'-3"	62'-8"	62'-2"	61'-7"	61'-1"	60'-6"	60'-0"
82.5	63'-6"	62'-11"	62'-4"	61'-9"	61'-2"	60'-7"	60'-0"
85	63'-9"	63'-1"	62'-6"	61'-10"	61'-3"	60'-7"	60'-0"
87.5	63'-11"	63'-3"	62'-7"	61'-11"	61'-3"	60'-7"	60'-0"
90	64'-0"	63'-4"	62'-8"	62'-0"	61'-4"	60'-8"	60'-0"

* NOTE: All values on this table are for required parking stalls. To determine parking bay widths for non-required stalls, merely use a column showing a stall width dimension that is 4 inches more. The values above the darkened lines are governed by minimum aisle width. The stall widths (8'-6", 8'-10", and 9'-2") are not shown in the ordinance, but are available for use.

TABLE 4: STANDARD CARS - PARKING BAY WIDTHS FOR TWO-WAY TRAFFIC AND SINGLE LOADED AISLES, BASED ON CHART NO. 4 IN ORDINANCE NO. 142,306 *

Parking Angle	8'-4" Stalls	8'-6" Stalls	8'-8" Stalls	8'-10" Stalls	9'-0" Stalls	9'-2" Stalls	9'-4" Stalls
30	35'-6"	35'-6"	35'-6"	35'-6"	35'-6"	35'-6"	35'-6"
32.5	36'-0"	36'-0"	36'-0"	36'-0"	36'-0"	36'-0"	36'-0"
35	36'-6"	36'-6"	36'-6"	36'-6"	36'-6"	36'-6"	36'-6"
37.5	37'-0"	37'-0"	37'-0"	37'-0"	37'-0"	37'-0"	37'-0"
40	37'-6"	37'-6"	37'-6"	37'-5"	37'-5"	37'-5"	37'-5"
42.5	38'-0"	38'-0"	37'-11"	37'-11"	37'-11"	37'-10"	37'-10"
45	38'-6"	38'-6"	38'-5"	38'-5"	38'-4"	38'-4"	38'-3"
47.5	39'-0"	38'-11"	38'-10"	38'-10"	38'-9"	38'-8"	38'-8"
50	39'-5"	39'-4"	39'-3"	39'-3"	39'-2"	39'-1"	39'-0"
52.5	39'-10"	39'-9"	39'-8"	39'-7"	39'-6"	39'-5"	39'-4"
55	40'-3"	40'-1"	40'-0"	39'-11"	39'-10"	39'-9"	39'-8"
57.5	40'-8"	40'-6"	40'-5"	40'-4"	40'-2"	40'-1"	40'-0"
60	41'-1"	40'-11"	40'-10"	40'-8"	40'-7"	40'-5"	40'-4"
62.5	41'-6"	41'-4"	41'-2"	41'-0"	40'-10"	40'-8"	40'-7"
65	41'-11"	41'-8"	41'-6"	41'-4"	41'-2"	41'-0"	40'-10"
67.5	42'-4"	42'-1"	41'-11"	41'-8"	41'-6"	41'-3"	41'-1"
70	42'-9"	42'-6"	42'-3"	42'-0"	41'-9"	41'-6"	41'-4"
72.5	43'-2"	42'-10"	42'-7"	42'-4"	42'-0"	41'-9"	41'-6"
75	43'-7"	43'-3"	42'-11"	42'-7"	42'-3"	41'-11"	41'-8"
77.5	44'-0"	43'-7"	43'-3"	42'-11"	42'-6"	42'-2"	41'-10"
80	44'-5"	44'-0"	43'-7"	43'-2"	42'-9"	42'-4"	41'-11"
82.5	44'-10"	44'-4"	43'-10"	43'-5"	42'-11"	42'-5"	42'-0"
85	45'-3"	44'-8"	44'-2"	43'-7"	43'-1"	42'-6"	42'-0"
87.5	45'-8"	45'-0"	44'-5"	43'-10"	43'-2"	42'-7"	42'-0"
90	46'-0"	45'-4"	44'-8"	44'-0"	43'-4"	42'-8"	42'-0"

* NOTE: All values on this table are for required parking stalls. To determine parking bay widths for non-required stalls, merely use a column showing a stall width dimension that is 4 inches more. The values above the darkened lines are governed by minimum aisle width. The stall widths (8'-6", 8'-10", and 9'-2") are not shown in the ordinance, but are available for use.

TABLE 5A: PARKING BAY DIMENSIONS FOR COMPACT CARS - REQUIRED STALLS

REQUIRED STALLS					
ONE WAY TRAFFIC			TWO WAY TRAFFIC		
ANGLE α	DOUBLE LOADED BAY WIDTH	SINGLE LOADED BAY WIDTH	ANGLE α	DOUBLE LOADED BAY WIDTH	SINGLE LOADED BAY WIDTH
30	40'-0"	26'-0"	30	48'-2"	34'-0"
32.5	40'-11"	26'-6"	32.5	49'-1"	34'-5"
35	41'-10"	26'-10"	35	49'-10"	34'-9"
37.5	42'-7"	27'-3"	37.5	50'-6"	35'-2"
40	43'-2"	27'-7"	40	50'-11"	35'-6"
42.5	43'-7"	27'-10"	42.5	51'-6"	35'-10"
45	44'-4"	28'-2"	45	52'-1"	36'-3"
47.5	45'-5"	29'-0"	47.5	52'-7"	36'-6"
50	46'-5"	29'-10"	50	52'-11"	36'-10"
52.5	47'-3"	30'-6"	52.5	53'-4"	37'-2"
55	48'-10"	31'-3"	55	53'-7"	37'-4"
57.5	48'-7"	31'-11"	57.5	53'-10"	37'-8"
60	49'-4"	32'-8"	60	54'-1"	37'-11"
62.5	50'-0"	33'-4"	62.5	54'-3"	38'-2"
65	50'-9"	33'-11"	65	54'-6"	38'-5"
67.5	51'-3"	34'-7"	67.5	54'-8"	38'-9"
70	51'-10"	35'-3"	70	54'-9"	38'-11"
72.5	52'-4"	35'-10"	72.5	54'-10"	39'-2"
75	52'-10"	36'-6"	75	54'-11"	39'-4"
77.5	53'-4"	37'-3"	77.5	55'-1"	39'-7"
80	53'-11"	37'-10"	80	55'-2"	39'-10"
82.5	54'-4"	38'-4"	82.5	55'-3"	39'-11"
85	54'-8"	39'-0"	85	55'-3"	40'-1"
87.5	55'-0"	39'-8"	87.5	55'-3"	40'-2"
90	55'-4"	40'-4"	90	55'-4"	40'-4"

As a covered entity under Title II of the Americans with Disabilities Act, the City of Los Angeles does not discriminate on the basis of disability and, upon request, will provide reasonable accommodation to ensure equal access to its programs, services and activities. For efficient handling of information internally and in the internet, conversion to this new format of code related and administrative information bulletins including MGD and RGA that were previously issued will allow flexibility and timely distribution of information to the public.

TABLE 5B: PARKING BAY DIMENSIONS FOR COMPACT CARS - NON-REQUIRED STALLS

NON-REQUIRED STALLS					
ONE WAY TRAFFIC			TWO WAY TRAFFIC		
ANGLE α	DOUBLE LOADED BAY WIDTH	SINGLE LOADED BAY WIDTH	ANGLE α	DOUBLE LOADED BAY WIDTH	SINGLE LOADED BAY WIDTH
30	40'-0"	26'-0"	30	48'-2"	34'-0"
32.5	40'-11"	26'-6"	32.5	49'-1"	34'-5"
35	41'-10"	26'-10"	35	49'-10"	34'-9"
37.5	42'-7"	27'-3"	37.5	50'-6"	35'-2"
40	43'-2"	27'-7"	40	51'-0"	35'-6"
42.5	43'-7"	27'-10"	42.5	51'-6"	35'-10"
45	44'-2"	28'-1"	45	52'-1"	36'-2"
47.5	44'-7"	28'-3"	47.5	52'-7"	36'-5"
50	45'-6"	29'-0"	50	52'-11"	36'-8"
52.5	46'-3"	29'-10"	52.5	53'-2"	37'-0"
55	47'-0"	30'-5"	55	53'-5"	37'-3"
57.5	47'-8"	31'-1"	57.5	53'-7"	37'-6"
60	48'-5"	31'-9"	60	53'-9"	37'-8"
62.5	49'-1"	32'-4"	62.5	53'-10"	37'-11"
65	49'-9"	32'-11"	65	54'-0"	38'-1"
67.5	50'-3"	33'-7"	67.5	54'-0"	38'-4"
70	50'-10"	34'-2"	70	54'-0"	38'-6"
72.5	51'-4"	34'-10"	72.5	54'-0"	38'-8"
75	51'-10"	35'-5"	75	54'-0"	38'-9"
77.5	52'-4"	36'-1"	77.5	54'-0"	38'-11"
80	52'-9"	36'-8"	80	54'-0"	39'-0"
82.5	53'-2"	37'-2"	82.5	54'-0"	39'-0"
85	53'-6"	37'-9"	85	54'-0"	39'-0"
87.5	53'-9"	38'-5"	87.5	54'-0"	39'-2"
90	54'-0"	39'-0"	90	54'-0"	39'-2"

As a covered entity under Title II of the Americans with Disabilities Act, the City of Los Angeles does not discriminate on the basis of disability and, upon request, will provide reasonable accommodation to ensure equal access to its programs, services and activities. For efficient handling of information internally and in the internet, conversion to this new format of code related and administrative information bulletins including MGD and RGA that were previously issued will allow flexibility and timely distribution of information to the public.

TABLE 6: ACCESS AISLE WIDTH FOR 90 DEGREE COMPACT AND STANDARD STALLS

STANDARD STALLS-RESIDENTIAL		STANDARD STALLS-ALL OTHERS		COMPACT STALLS	
STALL WIDTH	AISLE WIDTH	STALL WIDTH	AISLE WIDTH	STALL WIDTH	AISLE WIDTH
8'-6"	27'-4"	8'-4"	28'-0"	7'-6"	25'-4"
8'-8"	26'-8"	8'-8"	26'-8"	7'-10"	24'-0"
9'-0"	25'-4"	9'-0"	25'-4"	8'-2"	22'-8"
9'-4"	24'-0"	9'-4"	24'-0"	8'-4"	22'-0"
9'-6"	23'-4"	9'-6"	23'-4"	8'-6"	21'-4"
9'-8"	22'-8"	9'-8"	22'-8"	8'-8"	20'-8"
9'-10"	22'-0"	9'-10"	22'-0"	8'-10"	20'-0"

L. CALCULATION OF PARKING SPACES

To determine the number of parking spaces possible on a given sized lot or to determine the lot size required for a certain number of spaces, refer to Figure 3 and the following procedures:

1. To find the required Length (L) for a certain Number (N) of parking stalls:
 - a. Select Bay Width (B) from lot area that is available.
 - b. Using the parking bay charts or tables choose a trial Parking Angle, α (use maximum) and Stall Width, W (W is 8'-4" minimum for commercial required and non-required parking, 8'-6" minimum for residential required and non-required parking.)

NOTE: See Table 1 thru 4 for standard car stall and Tables 5A, 5B, and 6 for compact car stall bay width dimensions.

- c. From Figure 3 calculate the following values:

$$X = S \cos \alpha \quad Y = W / \sin \alpha \quad Z = W \sin \alpha$$

Then the Length (L) is the sum of the X, Y, and Z dimensions.

$$L = X + Z + (N-1) Y, \text{ which is (one stall) + (all stalls but one) } Y$$

2. To determine the Number (N) of parking stalls possible for an available parking bay of Length (L)

$$\text{Total number of parking spaces, } N = \frac{L - (X + Z)}{Y} + 1$$

3. For multiple parking bays where the bays overlap and interlock, the net bay widths may be determined by the parking bay relationships shown below:
 - a. Parking lot width for overlapping, interlocking bay widths, M (See Figure 3).
 - b. Compute parking bay overlap width, $Q = W \cos \alpha$ then determine required parking area width as follows:
 - i. For 2 interlocking bays, both double loaded: lot width = $2B - Q$, where b = width of single loaded bay
 - ii. For double and single loaded lot width = $B + b + Q$
 - iii. For multiple bays, all double loaded: lot width = $r(B - Q) + Q$, where r = number of bays
 - iv. One single loaded end bay: lot width = $r(B - Q) - b$
both end bays single loaded: lot width = $r(B - Q) + b$
4. Supplementary dimensions:
 - a. For angle α , parking stall depth, $P = S \sin \alpha + Q$
 - b. Driveway aisle width, D
double loaded bays, $D = B - 2P$
single loaded bays, $D = b - P$
5. Double loaded means parking on both sides of the driveway access aisle. Single loaded means parking on one side of the driveway access aisle.

M. STRIPING FOR ALL PARKING STALLS OTHER THAN THOSE SERVING A ONE FAMILY DWELLING

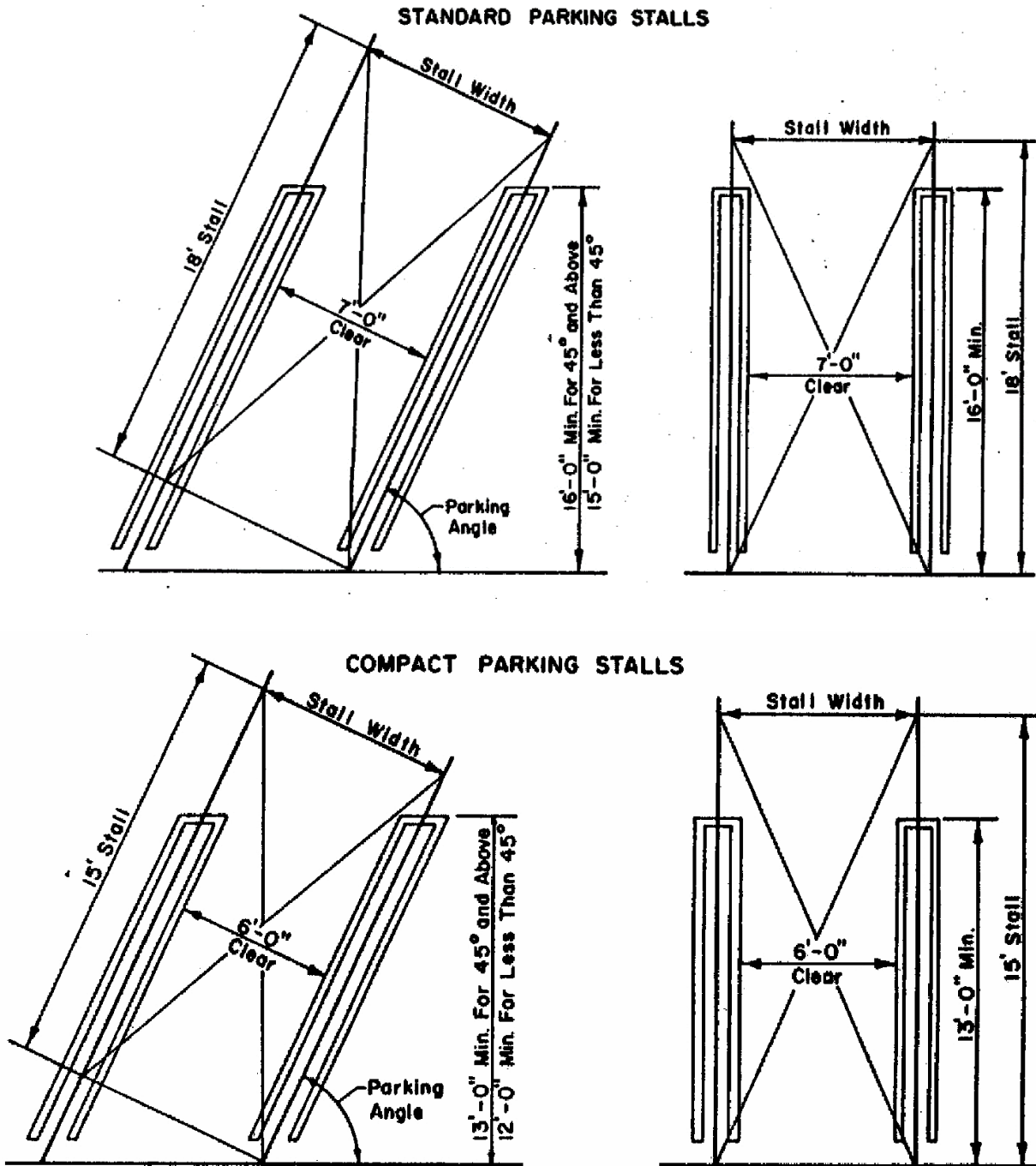

FIGURE 1

N. END STALL CONDITIONS

1. For end parking stalls placed at angles greater than 80 degrees, an increase of 3 ft. for standard stalls and 2 ft. for compact stalls to the Basic Stall Width (BSW) is required.
2. If access aisle extends a minimum of 3 ft. for standard stalls and 2 ft. for compact stalls beyond the end parking stall, no increase in stall width is required other than the 10 inch increase for obstructions. (See Figure 2 below)
3. The increase in stall width for end stall conditions or the extension of the access aisle beyond the end parking stall may be omitted if a minimum of 32 ft. wide access aisle is provided.
4. For standard stall with access aisle widths between 28 ft. and 32 ft., you can decrease the 3 ft. increase in stall width or extension of the access aisle by 6 ½ inches per foot of width of access aisle width beyond 28 ft.
5. For compact stalls, you can decrease the 2 ft. increase in stall width or extension of access aisle by 3 ½ inches per foot of width beyond 28 ft. of access aisle width.

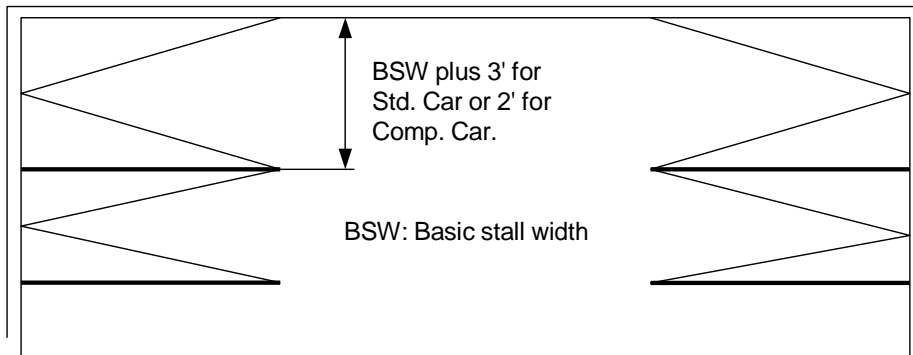
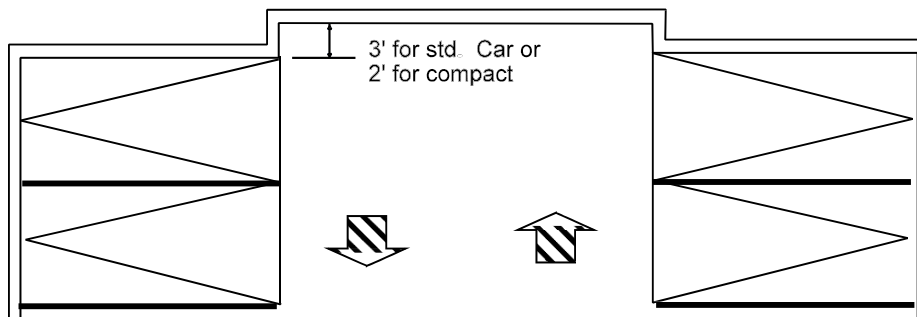

FIGURE 2



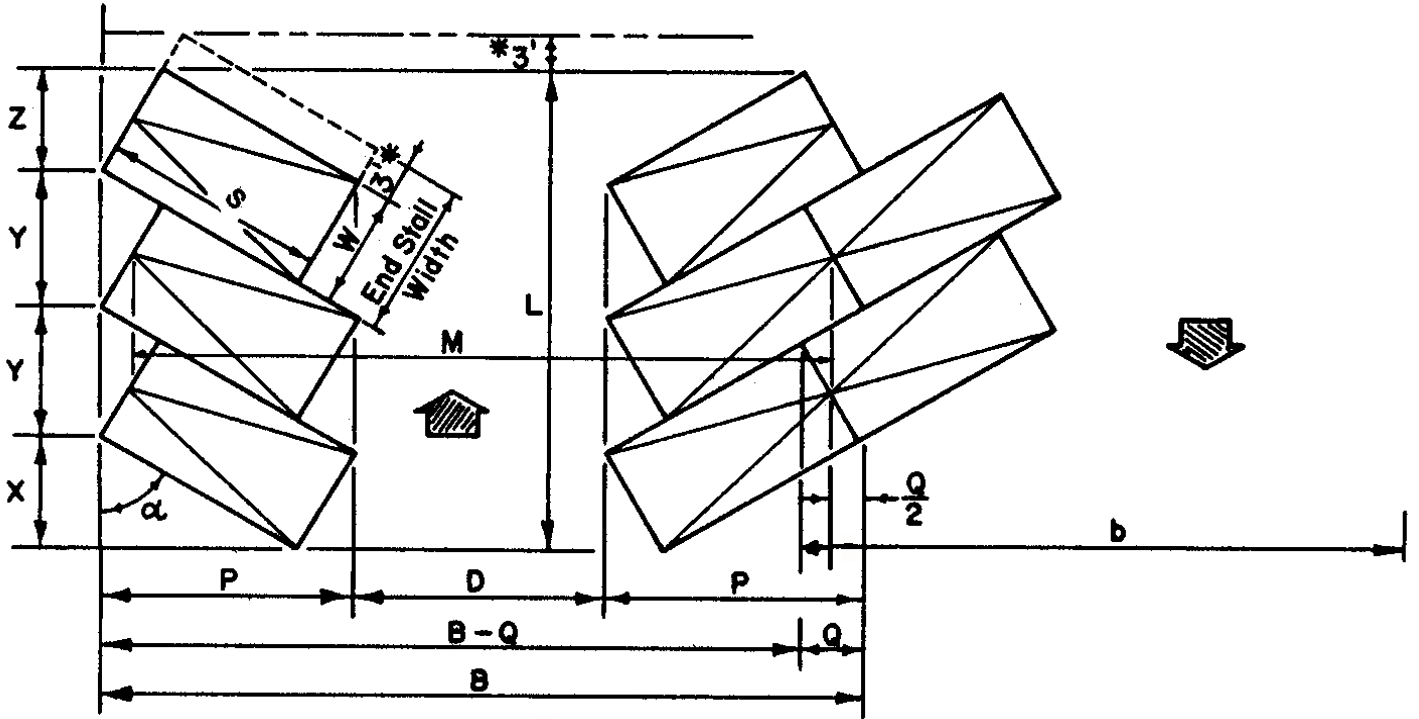

FIGURE 3

* End stalls for 82.5° to 90° parking shall be 3'-0" wider, or the access aisle shall extend 5' minimum beyond bay ($L + 3'$).

O. PARKING WALL HEIGHT

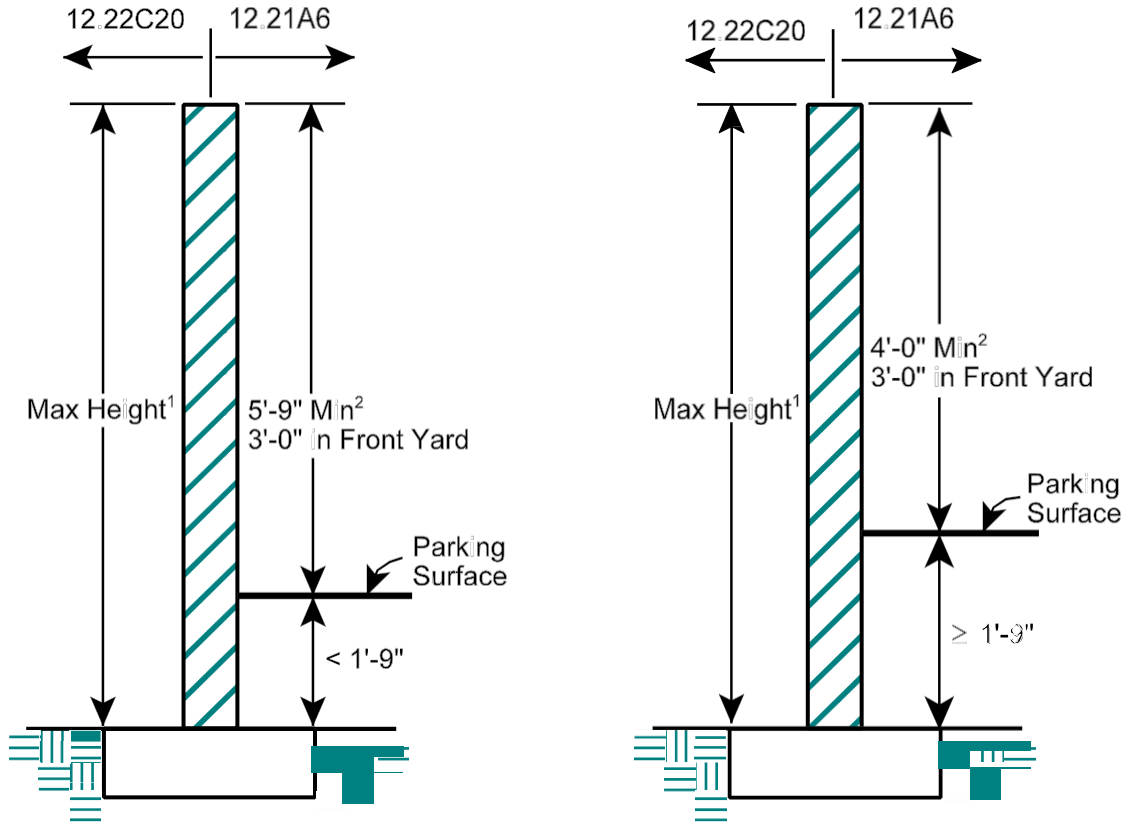

FIGURE 4

¹ Wall cannot exceed the height limitation as specified in 12.22C20(f) for “A” or “R” zones.

² Minimum height for parking wall is measured from the finished grade of the parking surface.

P. DRIVEWAY AND TURNING AREAS

FIGURE 5 - FOR PARALLEL PARKING

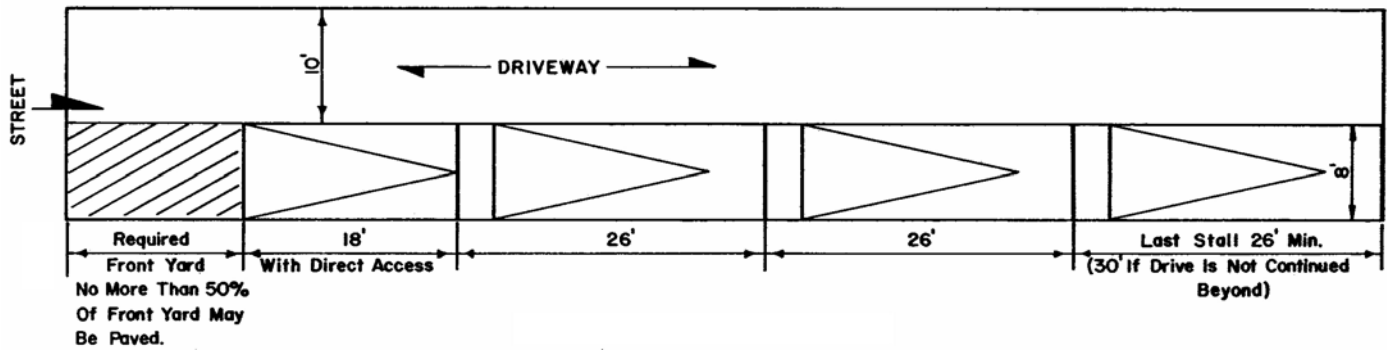

FIGURE 6 - CIRCULATION DRIVEWAYS FOR VARIOUS PARKING ANGLES

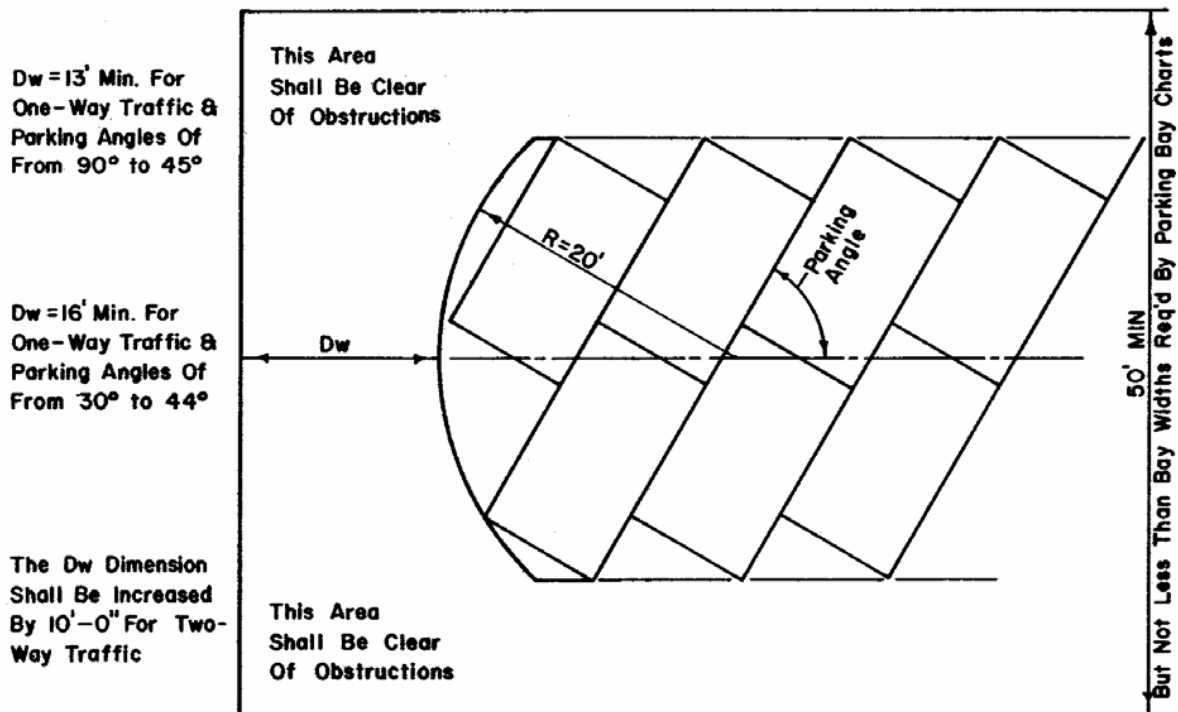
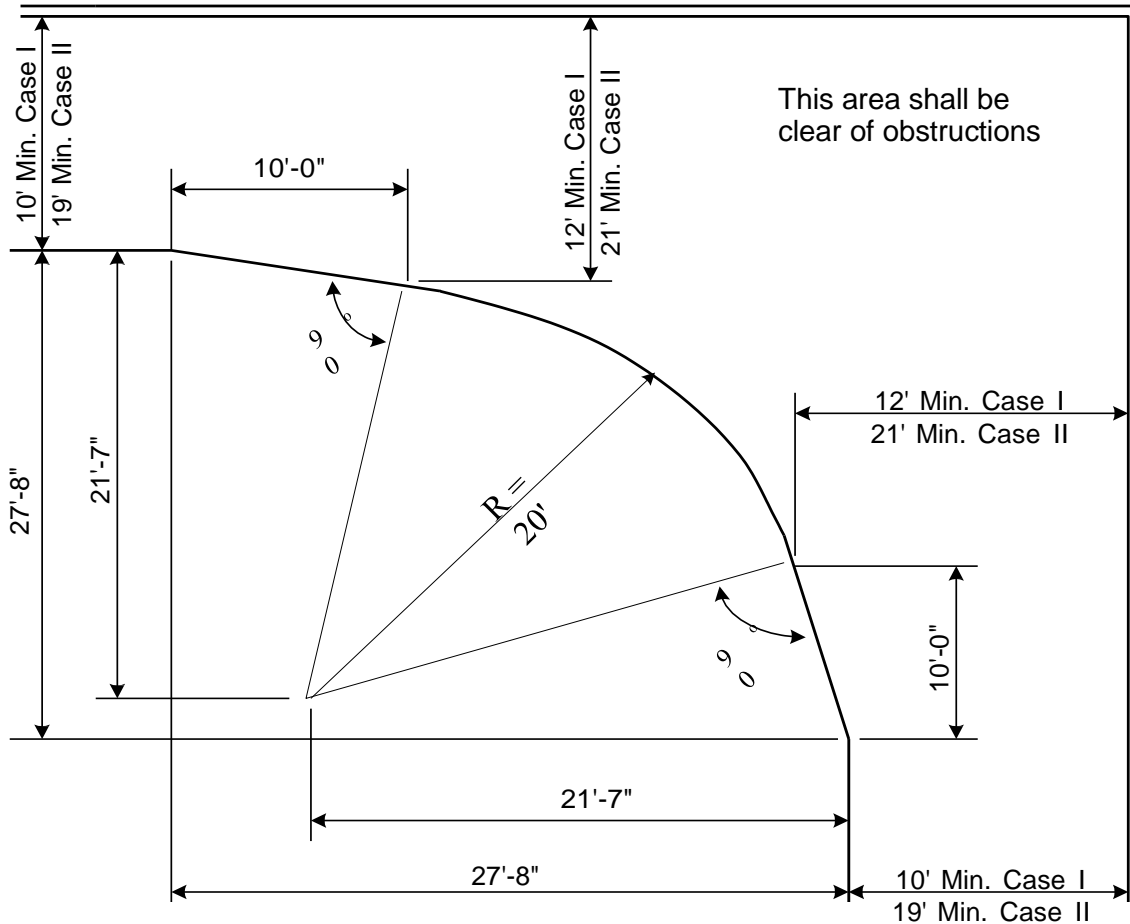

FIGURE 7 - CIRCULATION DRIVEWAYS

90° Turn
 (No Scale)



Case I - One-way traffic or two-way traffic where no more than 25 cars go around the turn.

Case II - Two-way traffic and more than 25 cars go around the turn.

FIGURE 8 - MINIMUM ACCESS AISLE PER TABLES 1 THROUGH 6

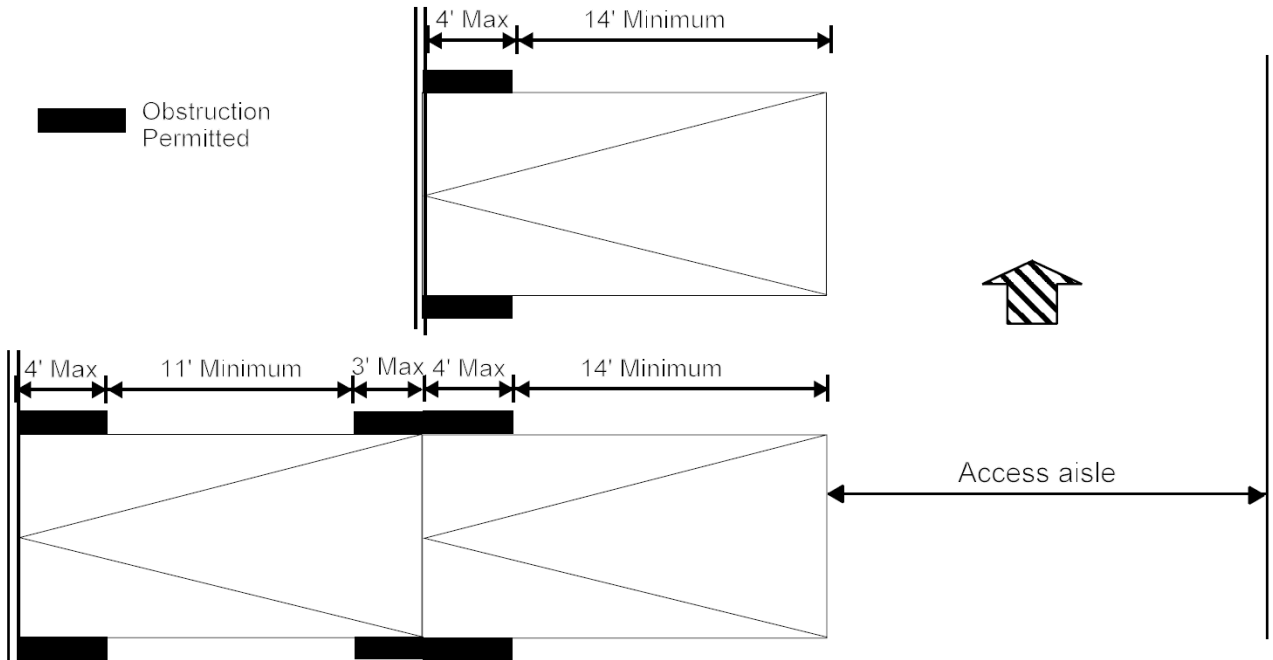
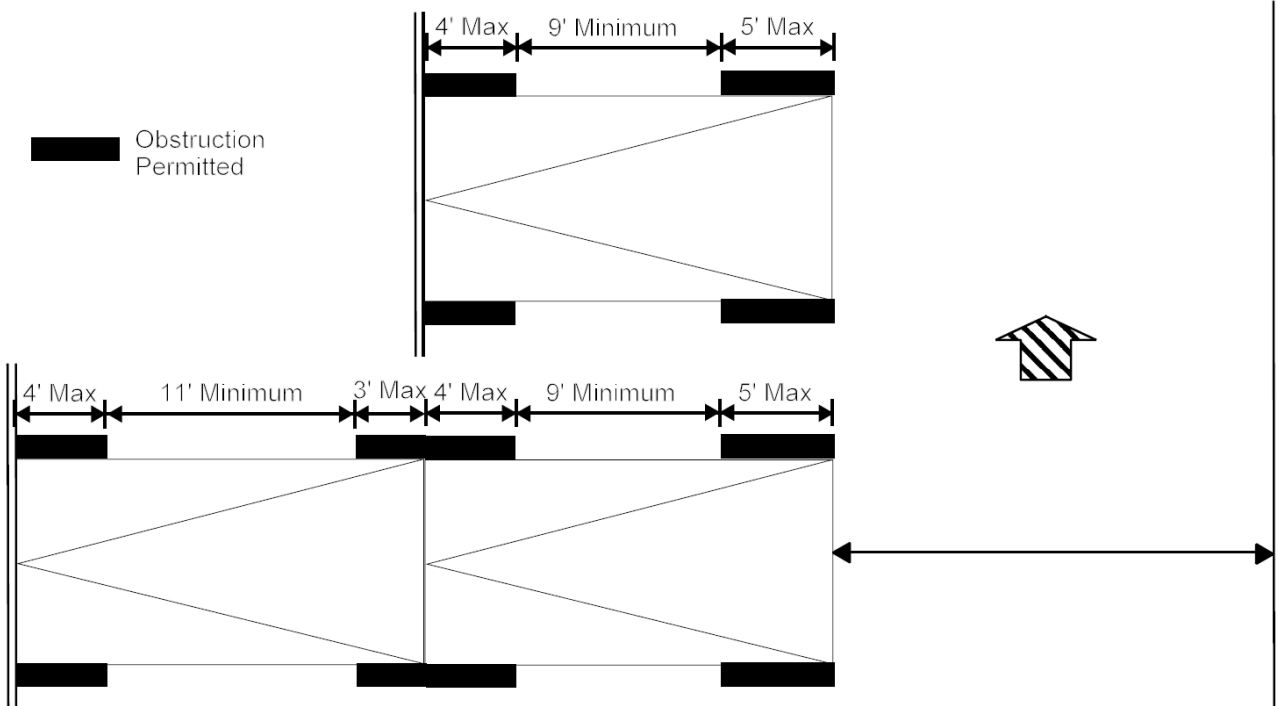

FIGURE 9 - MINIMUM ACCESS AISLE OF 28'-0" REQUIRED APARTMENTS AND CONDOMINIUM UNITS ONLY



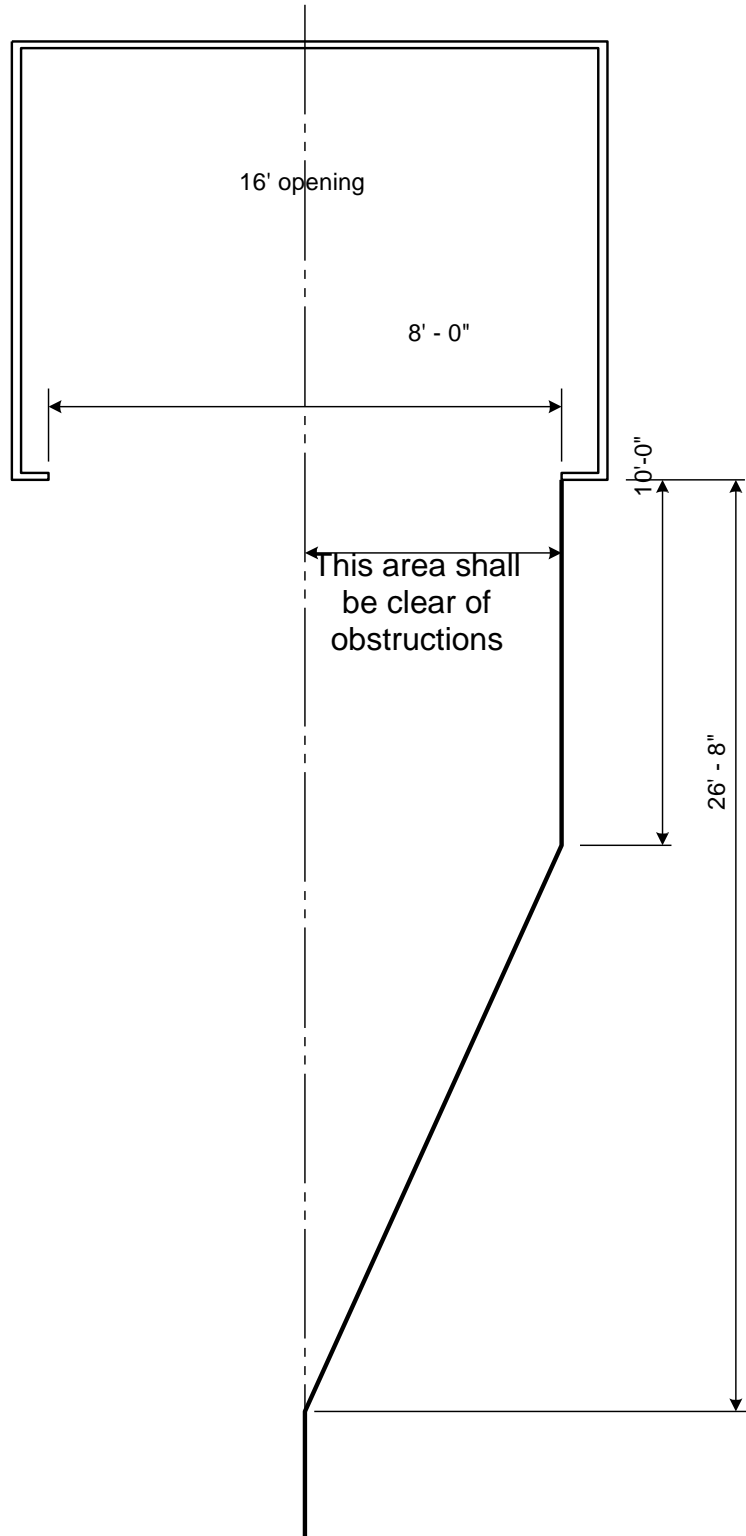
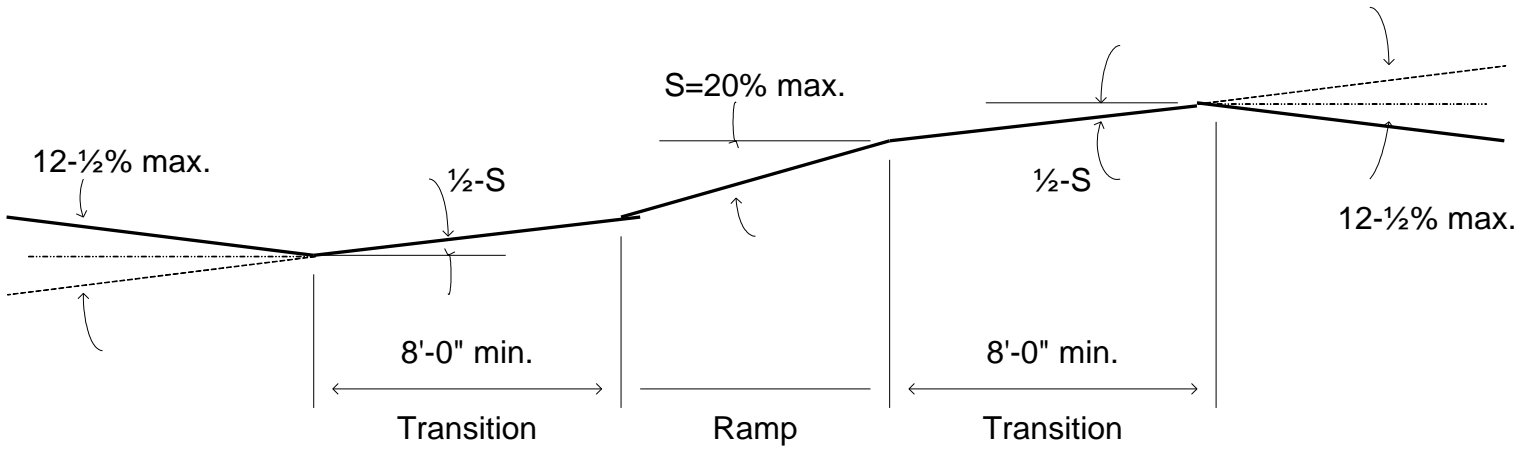

FIGURE 10: RESIDENTIAL GARAGE - TURNING CLEARANCE (FOR SINGLE FAMILY WELLINGS)



Note:
 Where ramp intersects the public way, the transition shall be designed as required by the Department of Public Works.

FIGURE 11B: DRIVEWAY TRANSITIONS (SIMPLIFIED DIAGRAM)

Q. MECHANICAL AUTOMOBILE PARKING LIFTS

Mechanical automobile parking lifts can be used to provide required parking spaces with the following conditions:

Types of mechanical automobile parking lifts that are covered by this section are:

- a. 2- post lifts
- b. Scissor lifts
- c. 4-post lifts

Other types of mechanical automobile parking lift system may be considered on case-by-case bases. See **Figure 12** below for graphical representation of the typical lifts.

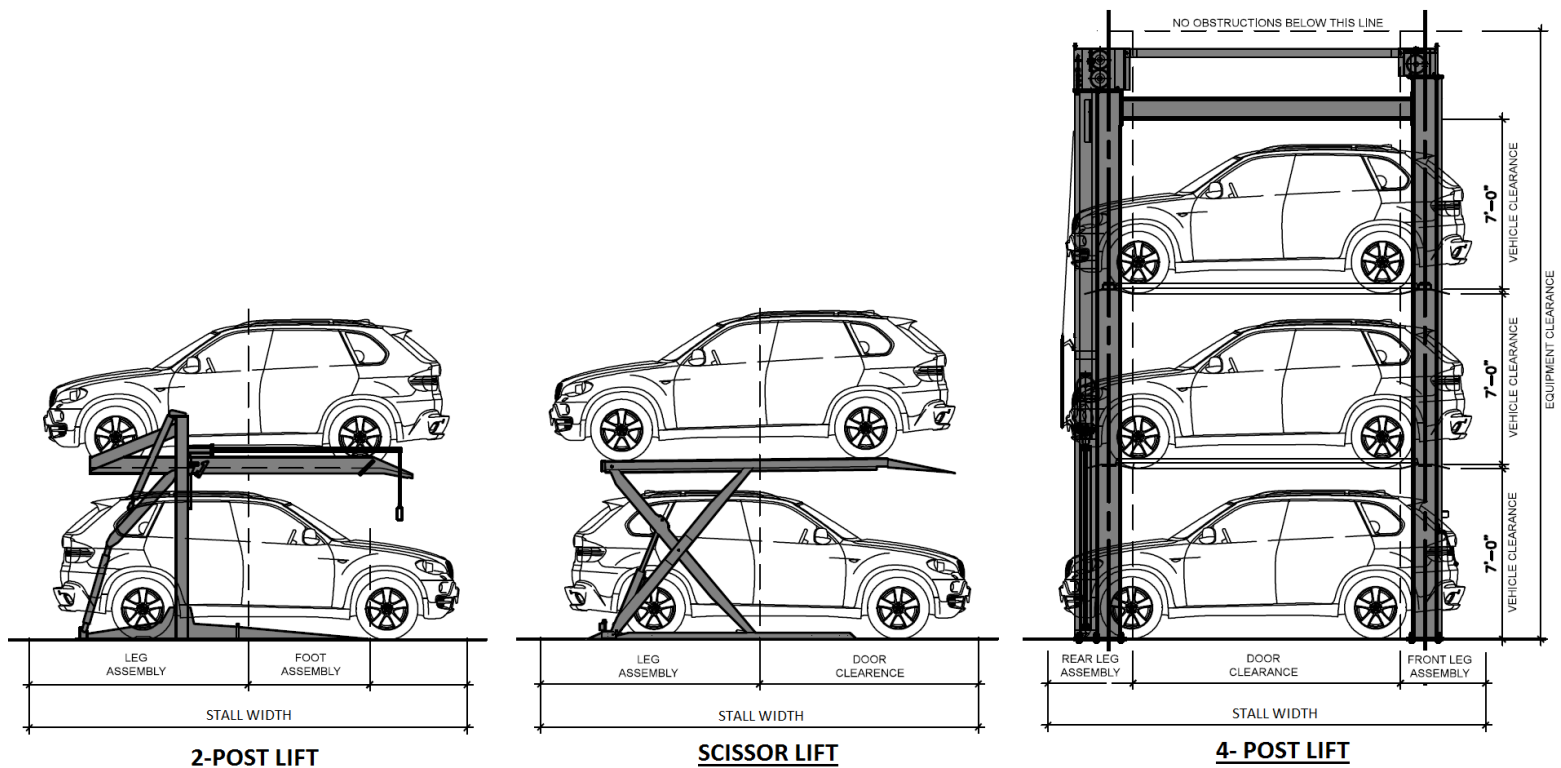

FIGURE 12- TYPES OF MECHANICAL AUTOMOBILE PARKING LIFTS

1. ZONING CODE REQUIREMENTS:

- A. The platform of the mechanical lift on which the automobile is first places shall be individually and easily accessible and shall be placed so that the location of the platform and vehicular access to the platform meets the LAMC Section 12.21A5(a), (b), and (i) requirements.
- B. Electrical Testing Laboratory approval is required for a mechanical automobile parking lifts. All of the conditions of approval shall be complied with.

- C. Mechanical automobile parking lifts must maintain the following clear width between vertical supports or any obstructions:
- a. Minimum 8'- 0" clear width for standard stalls
 - b. Minimum 7'- 0" clear width for compact stalls.

See **Figure 13** below for additional information.

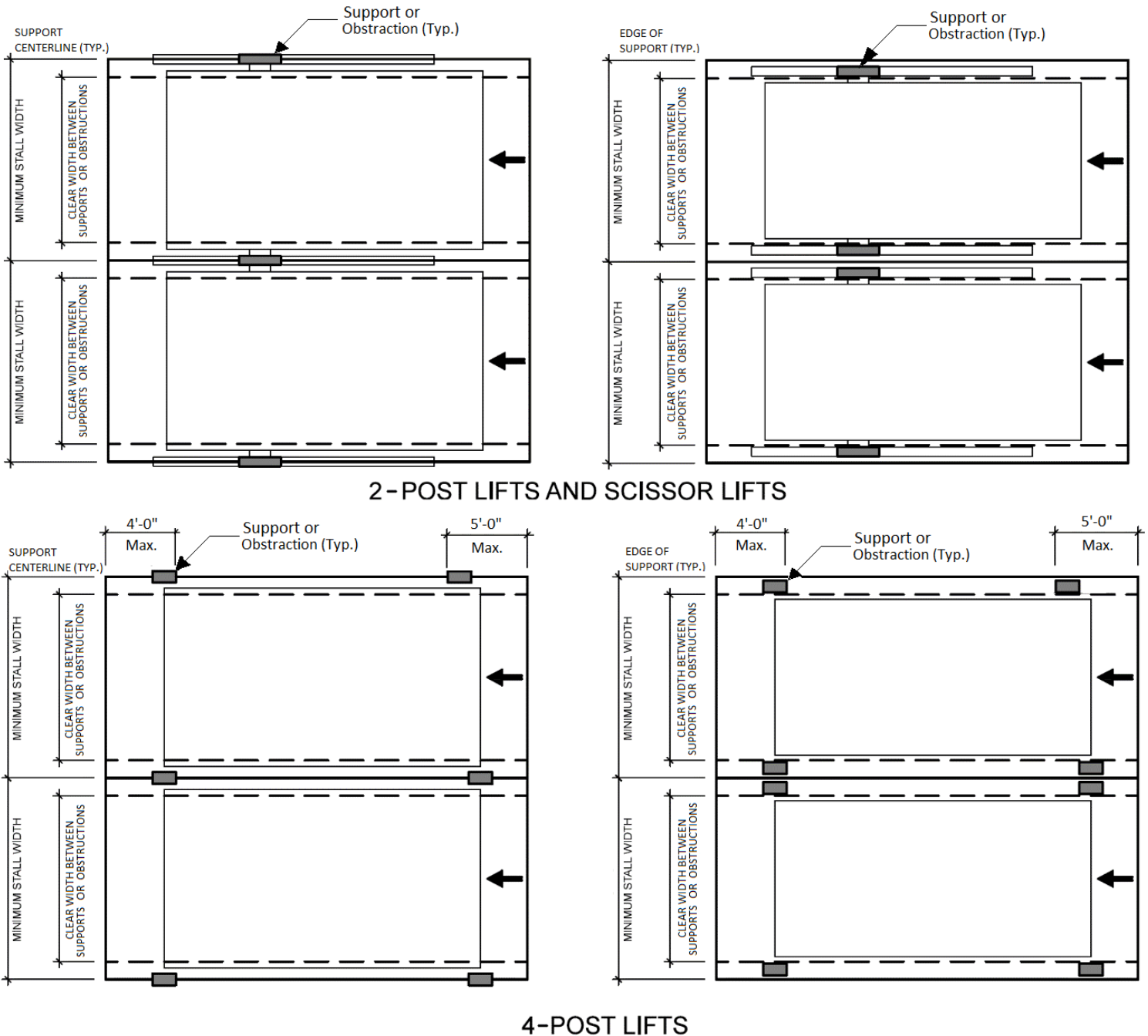
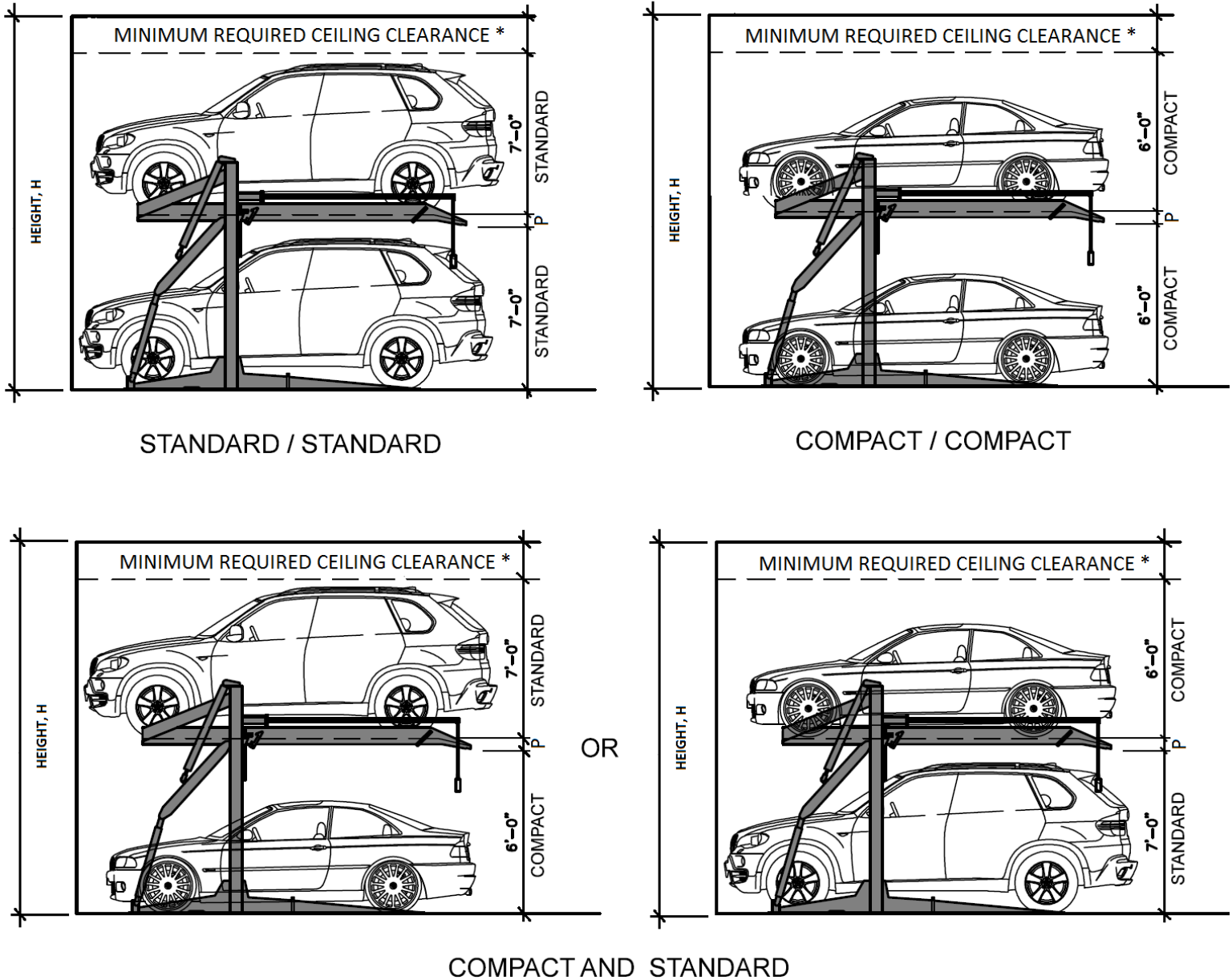

FIGURE 13- MINIMUM CLEAR WIDTH BETWEEN SUPPORTS AND OBSTRUCTIONS

- D. The stall heights within the mechanical automobile parking lifts shall be as follows:
- a. Minimum clear height of 7'-0" for standard stalls
 - b. Minimum clear height of 6'-0" for compact stalls

See **Figure 14** below for additional requirements.



* Minimum required clearance shall be 18" for sprinklers, or as-needed for roll-up doors.
 P = Platform thickness (See Manufacturer's Specifications)
 H = Height of any combination of the car type in stacked + P + Ceiling Clearance = Minimum clear floor to ceiling height required.

FIGURE 14- MINIMUM CLEAR HEIGHTS

- E. Mechanical automobile parking lifts must provide adequate door clearance for an attendant to exit a vehicle per manufactures specifications. See **Figure 12 and Figure 15** for additional information.

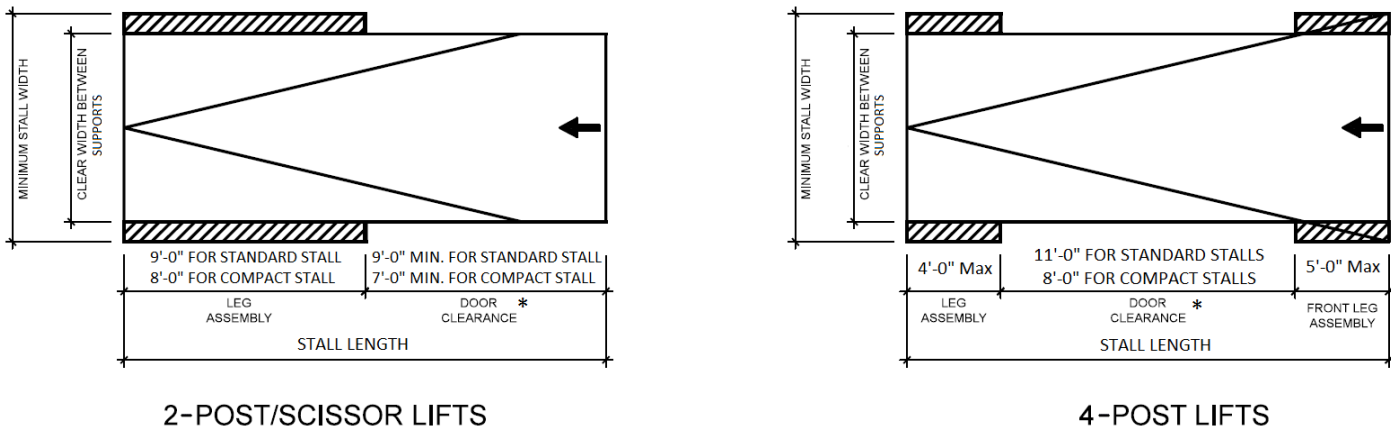

* Obstructions are not allowed within this area

FIGURE 15- VEHICLE DOOR CLEARANCES

- F. Mechanical automobile parking lifts shall be arranged in such a manner as to allow full operation of the sprinkler system. The required ceiling height may be reduced by up to 18 inches if the mechanical automobile parking lift is installed in a non-sprinklered garage, or when approval has been obtained from the Mechanical Plan Check for wall mounted Fire sprinklers **prior to Building Plan Check approval**. Additional headroom may be required to accommodate installation of roll-up garage doors.
- G. Mechanical automobile parking lifts are considered tandem parking. Therefore, they shall not be installed where tandem parking is prohibited, such as within a commercial corner lot development, mini-shopping center, for recreational vehicles or guest parking.
- H. In a private garage or private parking area, the tandem parking shall not be more than two-cars in depth [LAMC Section 12.21 A.5 (h)(2)]. Therefore, no parking spaces are permitted at the front and/or back of mechanical automobile parking lifts.
- I. A “Covenant and Agreement to Provide Parking Attendant” shall be recorded with LA County Recorder’s Office for tandem parking in public parking areas.
- J. When tandem parking is provided, parking area shall be capable of accommodating required onsite queuing spaces for the shuffling of cars. The queuing spaces shall be arranged so to that the required driveway access aisle is not reduce to less than 10’ wide. Each of the queuing spaces shall be minimum 8’ wide and 18’ long.
- K. A “Covenant and Agreement Regarding Maintenance of Vehicle Lift System” shall be recorded with LA County Recorder’s Office to maintain vehicle lift system in operable

conditions at all times. [Affidavit# 43A for a 2- level lifts](#) and [Affidavit# 43B for 3-level lifts](#). The copies of the forms can be obtained from www.LADBS.org.

- L. Installation of the mechanical automobile parking lift shall comply with the applicable provisions of the Los Angeles City Codes (Building, Electrical, Mechanical, Plumbing, and Fire Codes).
- M. Mechanical automobile parking lift shall comply with Los Angeles Fire Department (LAFD), [Fire Prevention Bureau and Public Safety Requirement No. 74](#). Refer to LAFD for additional information.
- N. Separate permit and approvals shall be obtained for the mechanical and electrical work.
- O. The mechanical automobile parking lift shall be installed on a level surface. The supporting structure and connections to the supporting structure shall be designed by the State of California licensed civil or structural engineer. The weight of the automobiles shall be included in determining the design seismic load.
- P. Mechanical Automobile parking lifts are not permitted within required front, side, or rear yards.

2. FIRE DEPARTMENT REQUIREMENTS

- A. Mechanical automobile parking lift shall comply with Los Angeles Fire Department (LAFD), [Fire Prevention Bureau and Public Safety Requirement No. 74](#). Refer to LAFD for additional information.

3. RECORDING OF AFFIDAVITS

- A. A “Covenant and Agreement to Provide Parking Attendant” shall be recorded with LA County Recorder’s Office for tandem parking in public parking areas.
- B. A “Covenant and Agreement Regarding Maintenance of Vehicle Lift System” shall be recorded with LA County Recorder’s Office to maintain the vehicle lift system in operable conditions at all times. [Affidavit# 43A for a 2- level lifts](#) and [Affidavit# 43B for 3-level lifts](#). The copies of the forms can be obtained from WWW.LADBS.ORG.

4. MATERIAL AND FABRICATION REQUIREMENTS

- A. **Structural Steel Materials:** Material tests or reports of tests made by a City of Los Angeles approved fabricator or test laboratory shall constitute sufficient evidence of conformity with one of the ASTM standards listed in Section A.3 1a of the ANSI/AISC360-16. For hot-rolled structural shapes, plates, such tests shall be made in accordance with

ASTM A568/A568M; for tubing and pipe, such tests shall be made in accordance with the requirements of the applicable ASTM standards listed above for those product forms.

ASTM Designations: Structural steel material conforming to one of the following ASTM specifications is approved for use under this Specification:

Hot-rolled structural shapes:

ASTM A36/A36M
ASTM A529/A529M
ASTM A572/A572M
ASTM A588/A588M
ASTM A709/A709M
ASTM A913/A913M
ASTM A992/A992M
ASTM A1043/A1043M

Hollow structural sections (HSS):

ASTM A53/A53M Grade B
ASTM A500/A500M
ASTM A501/A501M
ASTM A618/A618M
ASTM A847/A847M
ASTM A1065/A1065M
ASTM A1085/A1085M

Plates:

ASTM A36/A36M
ASTM A242/A242M
ASTM A283/A283M
ASTM A514/A514M
ASTM A529/A529M
ASTM A572/A572M
ASTM A588/A588M
ASTM A709/A709M
ASTM A1043/A1043M
ASTM A1066/A1066M

Bars:

ASTM A36/A36M
ASTM A529/A529M
ASTM A572/A572M
ASTM A709/A709M

Sheets:

ASTM A606/A606M
ASTM A1011/A1011M SS, HSLAS, and HSLAS-F

- B. Steel shall be fabricated by a City of Los Angeles Approved Fabricator. See the link below for the list of the City of Los Angeles approved fabricators <https://www.ladbsservices2.lacity.org/MATCRoster>

5. STRUCTURAL DESIGN REQUIREMENTS

- A. 2-Post Lifts and Scissor Lifts are considered as equipment. The supporting structures and connections to the supporting structures shall be designed by the State of California licensed civil or structural engineer in accordance with the 2023 Los Angeles Building Code. The weight of the automobiles shall be included in determining the seismic design load.
- B. 4-Post Lifts, where posts and beams are built to support the platforms/equipment, are considered as structures. A complete design of the structures, supporting structures, and connections (both gravity and lateral loads) shall be performed by the State of California licensed civil or structural engineer in accordance with the 2023 Los Angeles Building Code.
- C. Plans and calculations of the structures, supporting structures, and connections shall be submitted to the plan check section at the time of permit application. The plans and calculations shall be stamped and signed by a Civil or Structural Engineer registered in California.

6. ADDITIONAL REQUIREMENTS

- A. Electrical Testing Laboratory approval is required for mechanical automobile parking lifts. All of the conditions of approval shall be complied with.
- B. Installation of the mechanical automobile parking lift shall comply with the applicable provisions of the Los Angeles City Codes (Building, Electrical, Mechanical, Plumbing, and Fire Codes).
- C. Separate permits and approvals shall be obtained for the mechanical and electrical work.
- D. The mechanical automobile parking lift shall be installed on a level surface.